

**Introduction**

Type AQ & IQ Valve Position Monitors are designed to provide high accuracy feedback of valve position to plant control systems. These instructions outline the requirements for ensuring a long and trouble free service life from the monitors.

**Installation - Mounting**

Attach mounting plate (1) to the actuator using fasteners (2) and lockwashers (2a) provided with mounting kit (if supplied by Imtex).

Loosen indicator cover set screw (3) and rotate indicator cover (4) to desired viewing angle. Retighten set screw (3).

Rotate coupling spacer (5) and indicator drum (6) to desired position (OPEN or CLOSED appearing through indicator window).

Fit torque coupler (7) or NAMUR drive block (7a) using screw (8) supplied in kit.

Fit monitor assembly to actuator ensuring that the torque coupler/NAMUR drive block (7/7a) engages the pinion of the actuator (9). Secure the assembly using the bolts (10) and lockwashers (11) provided with the mounting kit.

Fine tune the indicator cover (4) by loosening set screw (3). Retighten set screw when completed.

Operate the actuator to ensure proper alignment between monitor and actuator. Eccentricity of the shaft must not exceed 0.25mm. If it should be necessary, re-align monitor by loosening mount bolts (10). Retighten bolts when satisfied with alignment.

**Installation - Wiring & Transmitter Setting**

Once the monitor is fitted to the actuator, remove cover (12). NOTE: On flameproof enclosures, the cover lock screw (13) must be loosened prior to cover removal.

Bring field wiring into the enclosure via the conduit entries (14) fitted with a suitable cable gland. Use blanking plugs to block off any un-used cable entries. NOTE: Suitable IP rated glands and plugs must be used to maintain monitor IP rating. On flameproof enclosures, only certified cable glands and blanking plugs can be used.

Connect field wiring to the terminals (15) within the enclosure according to the wiring diagram and terminal labelling.

NOTE: The Type AQ/IQ Transmitter is factory set to provide position information over a 90 Degree span.

Drive the actuator to the position intended to indicate the 'low' signal. Set the zero point for the transmitter either locally (when available) or using suitable configuration software.

Drive the actuator to the position intended to indicate the 'high' signal. Set the span point for the transmitter either locally (when available) or using suitable configuration software.

Once completed, verify that indication is required by fully stroking the actuator. Then refit cover (12). NOTE: On flameproof enclosures, the cover lock screw (13) must be retightened.

**SPECIAL CONDITIONS FOR FLAMEPROOF ENCLOSURES - ATEX**

Only certified cable glands and blanking plugs are permitted for use with ATEX certified, flameproof enclosures.

Monitor must be disconnected from the power supply and the cover screw (13) loosened before opening.

**Maintenance**

The Type AQ & IQ should offer years of reliable service, if installed correctly. However, it is advisable to check mounting screws/bolts, o-rings and terminal wiring for signs of loosening or corrosion as part of the routine plant maintenance to ensure continued trouble free operation.

MONITOR - TRANSMITTER - AQ/IQ70

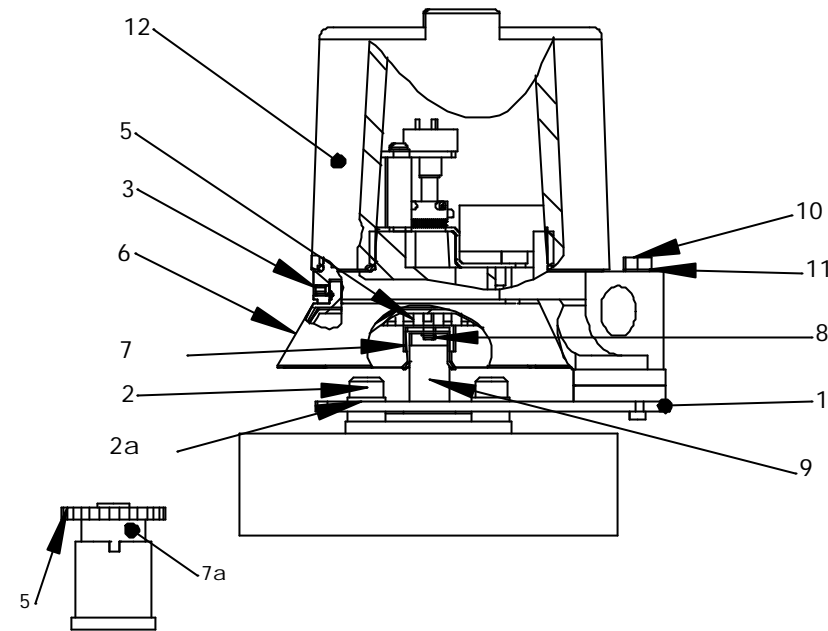
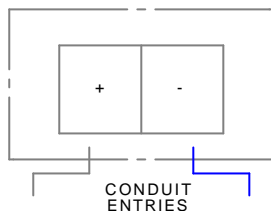

NAMUR Coupler

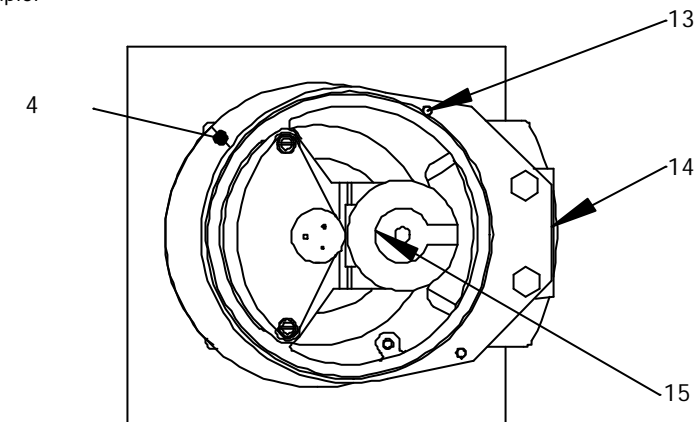

**AQ/IQ70 - Analogue/Digital Transmitter**

Supply Voltage: 8 to 30VDC  
 Internal Consumption: 25mW to 0.8W  
 Voltage Drop: 8VDC  
 Warm Up Time: 5 min  
 Comms Link: Loop  
 Signal / Noise Ratio: min 60 dB  
 Min Response Time: 0.33 s  
 Calibration Temp: +20 to +28 Deg C  
 Op Temp Range: -40 to +60 Deg C

REV	DRAWN PT	DATE	CHK'D	ECO
		7.2.07		06-474

UNLESS OTHERWISE SPECIFIED:  
 DIMENSIONS ARE IN MILLIMETERS  
 SURFACE FINISH:  
 TOLERANCES:  
 LINEAR:  
 ANGULAR:

TITLE:  
**Installation, Operating & Maintenance**

**AQ/IQ70**

DEBUR AND  
 BREAK SHARP  
 EDGES

DWG NO.

**A190123**

A4

MATERIAL:

WEIGHT(g):

SCALE:1:5

SHEET 1 OF 1

This private & confidential drawing is the property of Imtex Controls Limited, Tonbridge, UK and cannot be copied or reproduced without the express written permission of the Company.

**Imtex Controls Limited**  
 Unit 5A, Valley Industries, Hadlow Road  
 Tonbridge, Kent, TN11 0AH. United Kingdom  
 Tel: +44(0)1732-850360 Fax: +44(0)1732-852133  
 Website: [www.imtex-controls.com](http://www.imtex-controls.com)