

## Instructions

Type IQ Valve Position Monitors are designed to provide high accuracy feedback of valve position to plant control systems. These instructions outline the requirements for ensuring a long and trouble free service life from the monitors.

### Installation - Mounting

Attach mounting plate (1) to the actuator using fasteners (2) and lockwashers (2a) provided with mounting kit (if supplied by Imtex).

Loosen indicator cover set screw (3) and rotate indicator cover (4) to desired viewing angle. Retighten set screw (3).

Rotate coupling spacer (5) and indicator drum (6) to desired position (OPEN or CLOSED appearing through indicator window).

Fit torque coupler (7) or NAMUR drive block (7a) using screw (8) supplied in kit.

Fit monitor assembly to actuator ensuring that the torque coupler/NAMUR drive block (7/7a) engages the pinion of the actuator (9). Secure the assembly using the bolts (10) and lockwashers (11) provided with the mounting kit.

Fine tune the indicator cover (4) by loosening set screw (3). Retighten set screw when completed.

Operate the actuator to ensure proper alignment between monitor and actuator. Eccentricity of the shaft must not exceed 0.25mm. If it should be necessary, re-align monitor by loosening mount bolts (10). Retighten bolts when satisfied with alignment.

### Installation - Wiring & Switch Setting

Once the monitor is fitted to the actuator, remove cover (12). NOTE: On flameproof enclosures, the cover lock screw (13) must be loosened prior to cover removal.

Bring field wiring into the enclosure via the conduit entries (14) fitted with a suitable cable gland. Use blanking plugs to block off any un-used cable entries. NOTE: Suitable IP rated glands and plugs must be used to maintain monitor IP rating. On flameproof enclosures, only certified cable glands and blanking plugs can be used.

Connect field wiring to the terminals (15) within the enclosure according to the wiring diagram and terminal labelling. Connect earth conductor (which forms part of the supply cable) to the internal earth point (18).

Drive the actuator to the first required indication position and set the bottom switch by lifting and rotating the bottom cam (16). Secure the cam by allowing it to fully re-engage with the spline (17).

Repeat the process for each switch in-turn by lifting/pushing down the appropriate cam, rotating and re-engaging when desired position is reached

Once completed, verify that indication is required by fully stroking the actuator. Then refit cover (12). NOTE: On flameproof enclosures, the cover lock screw (13) must be retightened.

### SPECIAL CONDITIONS FOR FLAMEPROOF ENCLOSURES - ATEX / IECEx

Installation should be carried out by suitably trained personnel to an applicable Code of Practice (eg IEC/EN60079-14 & IEC/EN61241-14).

Only suitably certified and temperature rated cable glands and blanking plugs are permitted for use with ATEX/IECEx flameproof enclosures.

WARNING - The cable entry temperature rise is deg C above ambient - ensure use of suitably temperature rated cable & gland.

 WARNING - Electrostatic Hazard: Clean Only with a Damp Cloth.

WARNING - Do not install on an external source of heating or cooling e.g. by hot/cold air blowing temperature units

WARNING - Locate monitor to prevent propagating brush discharges

WARNING - Monitor should not be opened when energised or an explosive atmosphere may be present. The cover screw (13) must be loosened before opening and re-tightened before the monitor re-enters service.

The maximum constructional gap ( $i_c$ ) is less than that required by Table 2 of IEC 60079-1:2007 clause 5.2.2 as detailed below:

Flamepath - Push Rod and Main Body  
Max Gap (mm) - 0.1  
Comment - Cylindrical Spigot Joint

### Maintenance

The Type IQ requires no servicing during normal working life, if installed correctly. However, it is advisable to check mounting screws/bolts, o-rings and terminal wiring for signs of loosening or corrosion as part of the routine plant maintenance to ensure continued operation. Ensure safety warnings are observed during maintenance. Inspection & maintenance to ATEX/IECEx flameproof enclosures to be carried out by suitably trained personnel with applicable code of practice (eg IEC/EN60079-17 & IEC/EN61241-17). Repairs to Type IQ ATEX/IECEx flameproof enclosures are not permitted. Please consult factory.

## Reference Diagram

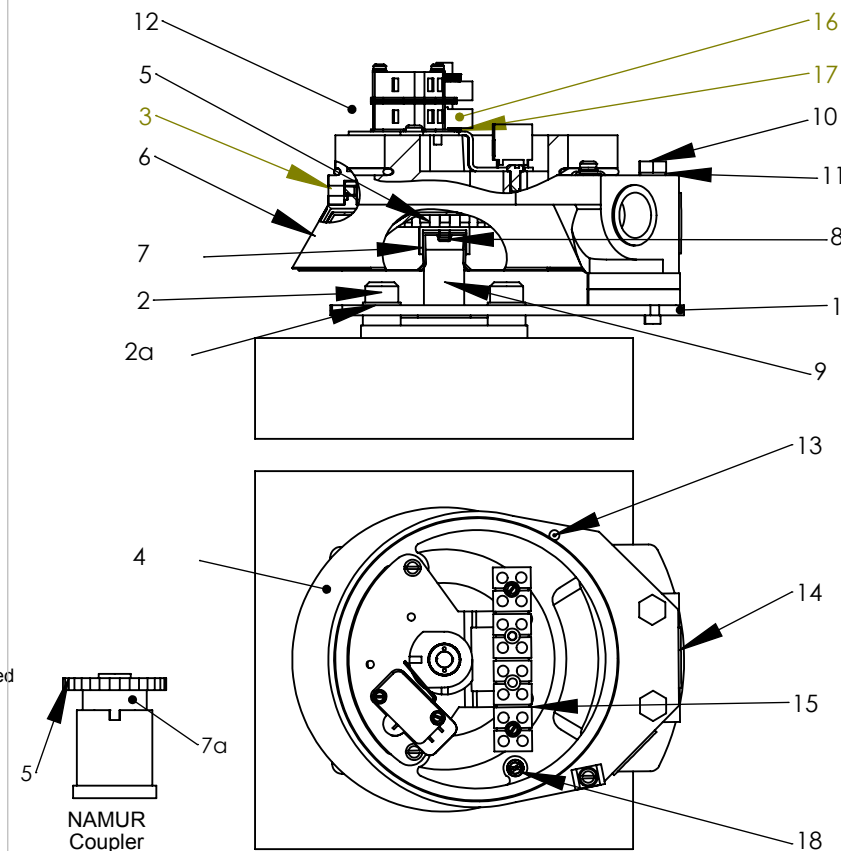

### Additional Instructions for Safe Use

The certification for this monitor relies upon the following materials used in its construction:

- Stainless Steel
- EDPM 70 or Viton V700-75 Seals (depending on operating temperatures)

If the equipment is likely to come into contact with aggressive substances, then it is the responsibility of the user to take suitable precautions that prevent it from being adversely affected, thus ensuring that the type of protection provided by the equipment is not compromised. Aggressive substances might be: acidic liquids or gases that attack Stainless Steel, or direct and prolonged contact with some Hydrocarbons that could affect the seals. Regular checks/inspections should be carried out if aggressive substances are present.

REV	DRAWN	DATE	CHK'D	ECO
	PT	15.6.09		09-1084

**Imtex Controls Limited**  
Unit 5A, Valley Industries, Hadlow Road  
Tonbridge, Kent, TN11 0AH, United Kingdom  
Tel: +44(0)1732-850360 Fax: +44(0)1732-852133  
[Website: www.imtex-controls.com](http://www.imtex-controls.com)

UNLESS OTHERWISE SPECIFIED:  
DIMENSIONS ARE IN MILLIMETERS  
SURFACE FINISH:  
TOLERANCES:  
LINEAR:  
ANGULAR:

DEBUR AND  
BREAK SHARP  
EDGES

MATERIAL:  
WEIGHT(g):

TITLE:

Installation, Operating & Maintenance

IQ42 & 52 - IECEx/ATEX

DWG NO.

**A190210**

A4

SCALE:1:5

SHEET 1 OF 2

### Wiring Diagrams and Operating Data

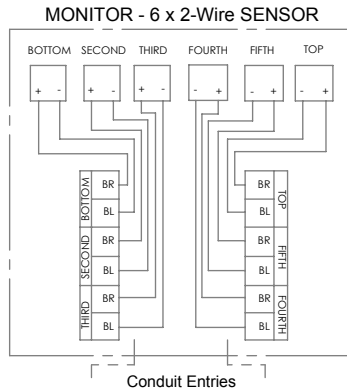
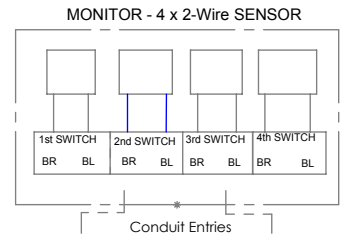
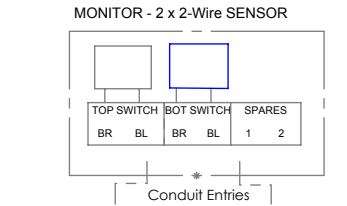

#### AQ/IQ42 & 52 - NAMUR Proximity Sensor

Current Ratings: Target Present - Current < 1.0mA  
 Target Absent - Current > 3.0mA  
 Voltage Range: 5 to 25VDC (nominal 8VDC)  
 Temp Range: -25 to +72 Deg C  
 Operating Life: Unlimited Cycles

Use with intrinsically safe repeater barrier. Namur sensors fully conform to EN60947-5-6 (VDE0660 Part 212) standard.

### Referenced Standards

The following standards have been referred to in these instructions and are applicable to the use of this product when used in an environment where an explosive atmosphere may be present:

- IEC 60079-0:2007 5th Ed
- IEC60079-1:2007 6th Ed
- IEC 61241-1:2004 1st Ed
- EN60079-0:2006
- EN60079-1:2007
- EN61241-0:2006
- EN61241-1:2004

### Cable Entries

The number and type of cable entry on the Monitor can be determined by reference to the 6th digit of the monitor part number. For example, in part number -

IQ16S5SR

the sixth digit is a '5' which corresponds to the monitor having 2 off M20 x 1.5 cable entry. Refer to table below for details.

CABLE ENTRY GUIDE	
DIGIT	ENTRIES SUPPLIED
5	(2) M20 x 1.5
6	(3) M20 x 1.5
8	(1) 3/4" NPT (central entry) (1) 1/2" NPT (offset entry)
9	(1) 3/4" NPT (central entry) (2) 1/2" NPT (offset entry)
B	(2) 1/2" NPT
C	(3) 1/2" NPT

NPT Threads conform to ANSI/ASME B1.20.1 and shall be made up wrench tight

Metric Thread tolerance to ISO 965-1 and ISO 965-3

### Product Markings

The label on the monitor should be as below:

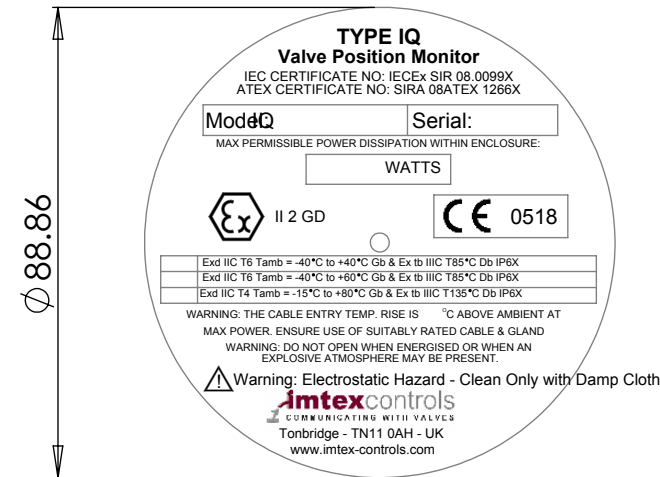

REV	DRAWN	DATE	CHK'D	ECO
	PT	15.6.09		09-1084

UNLESS OTHERWISE SPECIFIED:  
 DIMENSIONS ARE IN MILLIMETERS  
 SURFACE FINISH:  
 TOLERANCES:  
 LINEAR:  
 ANGULAR:

TITLE:  
**Installation, Operating & Maintenance**  
**IQ42 & 52 - IECEx/ATEX**

This private & confidential drawing is the property of Imtex Controls Limited, Tonbridge, UK and cannot be copied or reproduced without the express written permission of the Company.

**Imtex Controls Limited**  
 Unit 5A, Valley Industries, Hadlow Road  
 Tonbridge, Kent, TN11 0AH, United Kingdom  
 Tel:+44(0)1732-850360 Fax:+44(0)1732-852133  
 Website: [www.imtex-controls.com](http://www.imtex-controls.com)

DEBUR AND  
 BREAK SHARP  
 EDGES  
 MATERIAL:  
 WEIGHT(g):

DWG NO.

**A190210**

A4

SCALE:1:5

SHEET 2 OF 2